



INSTALLATION MANUAL

KD135SX-UFBS, KD140SX-UFBS

OF

SOLAR PHOTOVOLTAIC POWER MODULES

Please read this manual carefully before installing the modules.

6C-209964

1. INTRODUCTION

As the world leader in development and application of high technology ceramic/silica materials, Kyocera offers a wide range of highly efficient and reliable crystalline silicon solar photovoltaic (PV) power modules. Kyocera began to extensively research PV technology in 1975 and commenced manufacturing operations in 1978. Since then, Kyocera has supplied millions of cells and modules throughout the world. With years of experience and state-of-the-art technology, Kyocera provides the highest quality PV power modules in a range of sizes designed to meet the requirements of the most demanding energy and power users worldwide.

2. POWER MODULES

The KDxxxSX-UFBS series modules consist of a series of electrically interconnected crystalline silicon solar cells, which are permanently laminated within a pottant and encapsulated between a tempered glass cover plate and a back sheet. The entire laminate is secured within an anodized aluminum frame for structural strength, ease of installation, and to protect the cells from the most severe environmental conditions.

3. APPLICATIONS

The KDxxxSX-UFBS series modules are a reliable, virtually maintenance-free direct current (DC) power source, designed to operate at the highest level of efficiency. The KDxxxSX-UFBS series modules are ideal to remote homes, recreational vehicles, water pumps, telecommunication systems and many other applications either with or without using storage batteries.

4. WARNINGS & SAFETY

PV modules generate electricity when exposed to light. Arrays of many modules can cause lethal shock and burn hazards. Only authorized and trained personnel should have access to these modules. To reduce the risk of electrical shock or burns, modules may be covered with an opaque material during installation. Do not touch live terminals with bare hands. Use insulated tools for electrical connections. Do not use these PV modules for solar concentration.

WARNING

"SUITABLE FOR USE IN CLASS I, DIVISION 2, GROUPS A, B, C AND D HAZARDOUS LOCATIONS, OR NONHAZARDOUS LOCATIONS ONLY."

"WARNING - EXPLOSION HAZARD - DO NOT DISCONNECT EQUIPMENT WHILE THE CIRCUIT IS LIVE OR UNLESS THE AREA IS KNOWN TO BE FREE OF IGNITABLE CONCENTRATIONS."

"WARNING - EXPLOSION HAZARD - SUBSTITUTION OF ANY COMPONENT MAY IMPAIR SUITABILITY FOR CLASS I, DIVISION 2."

PERMIT

- Before installing your PV system, contact local authorities to determine the necessary permits, installation and inspection requirements.

INSTALLATION AND OPERATION

- Systems should be installed by qualified personnel only. The system involves electricity, and can be dangerous if the personnel are not familiar with the appropriate safety procedures.
- **Do not step on a PV module.**
- Although the KDxxxSX-UFBS series modules are quite durable, the glass can be broken (and PV module will no longer work properly) if it is dropped or hit by tools or other objects.

- The module frame is made of anodized aluminum, and therefore corrosion can occur if the module is subject to a salt-water environment and/or is in contact with another type of metal (galvanic corrosion). If required, PVC or stainless steel washers can be placed between the PV module frame and the support structure to prevent this type of corrosion.
- The KDxxxSX-UFBS series module frame(s) must be attached to a support structure by one of the methods described in Section 7, INSTALLING THE KDxxxSX-UFBS SERIES MODULES.
- Module support structures to be used to support the KDxxxSX-UFBS series module(s) should be wind rated and approved by the appropriate local and civil codes prior to installation.
- Do not expose the back of the module to direct sunlight.
- In Canada installation shall be in accordance with CSA C22.1, Safety Standard for Electrical Installations, Canadian Electrical Code, Part 1.

FIRE RATING

- In case of roof installation, the PV module assembly shall be mounted on a fire resistant roof covering rated for the application. The KDxxxSX-UFBS series modules are comprised of a glass front surface, polyethylene terephthalate (PET) back sheet with a Class C fire rating.

GROUNDING

- Refer to "Grounding" section.

BATTERY

- When PV modules are used to charge batteries, the battery must be installed in a manner, which will ensure the performance of the system and the safety of its users. **Follow the battery manufacturer's safety guidelines concerning installation, operation and maintenance recommendations.** In general, the battery (or battery bank) should be kept away from people and animals. Select a battery site that is protected from sunlight, rain, snow, debris, and is well ventilated. Most batteries generate hydrogen gas when charging, which can be explosive. Do not light matches or create sparks near the battery bank. When a battery is installed outdoors, it should be placed in an insulated and ventilated battery case specifically designed for this purpose.

5. SITE SELECTION

In most applications, the KDxxxSX-UFBS series modules should be installed in a location where they will receive maximum sunlight throughout the year. In the Northern Hemisphere, the modules should typically face south, and in the Southern Hemisphere, the modules should typically face north. Modules facing 30 degrees away from true South (or North) will lose approximately 10 to 15 percent of their power output. If the module faces 60 degrees away from true South (or North), the power loss will be 20 to 30 percent. When choosing a site, avoid trees, buildings or obstructions, which could cast shadows on PV modules especially during the winter season when the arc of the sun is lowest over the horizon.

6. MODULE TILT ANGLE

The KDxxxSX-UFBS series modules produce more power when they are pointed directly at the sun. For stand alone installations PV modules should be tilted for optimum winter performance. As a general rule, if the system power production is adequate in the winter, it will be satisfactory during the rest of the year. PV module tilt angle is measured between PV modules and the ground. Refer to the recommended module tilt angle table for your site.

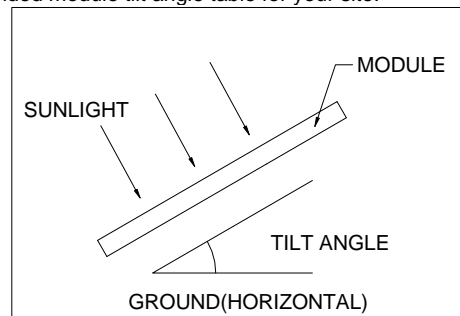

Figure 1. Module Tilt Angle

Table 1. Recommended Tilt Angles for Stand Alone Fixed Systems - Based on Winter Performance

| SITE LATITUDE IN DEGREES | FIXED TILT ANGLE |
|--------------------------|------------------|
| 0° TO 15 | 15° |
| 15° TO 25° | SAME AS LATITUDE |
| 25° TO 30° | LATITUDE + 5° |
| 30° TO 35° | LATITUDE + 10° |
| 35° TO 40° | LATITUDE + 15° |
| 40° + | LATITUDE + 20° |

For grid tie installations where the solar modules are attached to a permanent structure, PV modules should be tilted at an angle equal to the site's latitude. This will typically result in the highest annual energy output.

7. INSTALLING THE KDxxxSX-UFBS SERIES MODULES

The minimum spacing of 2" (50mm) is required between the PV module and the mounting surface around the perimeter of PV module. The frame of each PV module has 0.35" (9mm) diameter mounting holes (Refer to Module Mounting Specifications). These are used for fixing PV modules to the supporting structure. PV module frames must be attached to a support structure using M8 (5/16") stainless steel screw in a minimum of four (4) places symmetrical on PV module. The stainless steel screw used for fixing the module frame should secure with an adequate torque. (usually, 19 N-m (14 ft-lb).) An example of a ground mounted structure is shown in Figure 2. The four holes close to the corners of the module are most often used for installation. Refer to the Mounting Specifications for the position of these holes. Clearance between PV module frame and the mounting surface may be required to prevent the junction box from touching the surface, and to circulate cooling air around the back of PV module. Spacing between PV modules must be a minimum of 1/8" (3.2 mm) to allow for thermal expansion. If the modules are to be installed on the roof or wall of a building, the stand-off method or the rack method is recommended.

STAND-OFF METHOD: PV modules are supported parallel to the surface of the building wall or roof. Clearance between PV module frames and surface of the wall or roof is required to prevent PV module and / or wiring from damage. The recommended stand-off height is 4.5" (about 115 mm). If other mounting means are employed, this may affect the Listing For Fire Class Ratings.

RACK METHOD: The supporting frame is used to mount PV modules at correct tilt angles. PV modules specified in this installation manual are not designed for Building Integrated Photovoltaic (B.I.P.V) application as part of a roof or wall. The mounting design may have an impact on the fire resistance.

OTHER: Other method(s) certified by a registered professional engineer, and in compliance with local codes.

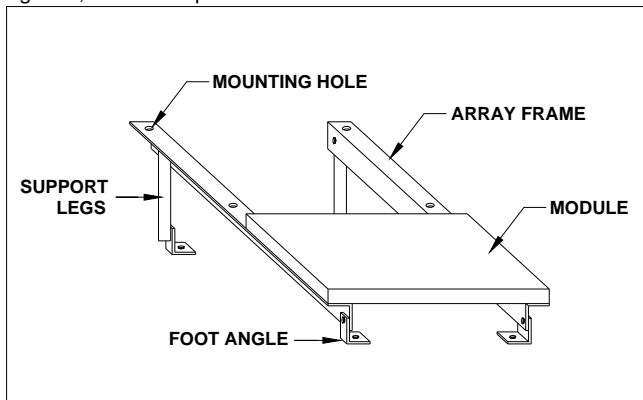

Figure 2. Basic Rack or Stand-off Mounting Structure

8. MODULE WIRING

As shown in Figure 3 Standard Wiring Examples, Kyocera PV modules utilize the Type "IM" junction box (see J-box details). This junction box, located on the back side of the module, is weatherproof and is designed to be used with standard wiring or conduit connections. A cable clamp with a minimum rating of IP65 must be used to maintain the weatherproof integrity of the junction box. Bypass diodes are preinstalled at factory.

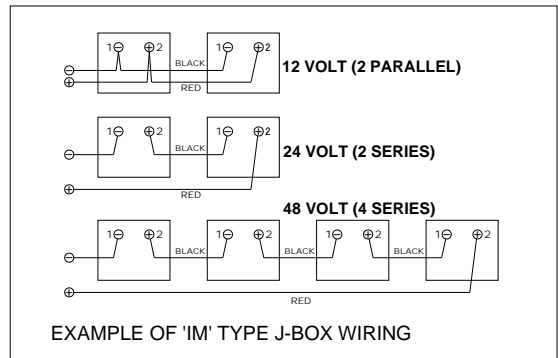

Figure 3. Standard Wiring Examples

To wire Kyocera PV modules:

- A. Determine the nominal system array voltage of your system. Each panel is equivalent to a 12 VDC nominal block. Standard array voltages 12, 24 and 48 volt are shown as examples in Figure 3.
- B. Open the "IM" box cover by loosening the screws in the cover.
- C. The wire used to interconnect PV modules may be single or two conductors, from 14AWG (2.08 mm²) up to 10AWG (5.26 mm²) gauge stranded copper wire, in a "SUNLIGHT RESISTANT" and insulated for 90°C minimum jacket cable. This cable is suitable for applications where wiring is exposed to the direct rays of the sun. The maximum and minimum outer diameters of the cable that may be used with the cable connector are 8 mm and 6 mm respectively (Figure 4).
- D. Using a flat blade screw driver, remove only the appropriate "KNOCK-OUTS" from the sides of the "IM" box.
- E. Route wires through the knock-outs and clamps refer to installation example (see Figure 5).
- F. Gently hand tighten the terminal screws with cross slot (Phillips -head) screwdriver. Do not over tighten, as the terminal can be damaged. (Recommendation Torque : 1.5N-m (13.3 in-lb))
- G. The output wiring from the final module is generally run to a separate array junction box. In commercial system, this wiring from the array box to the next component (i.e. fuse box. or charge regulator, etc.) is generally run in conduit. The maximum electrical rating of an acceptable series fuse is 15 amperes.
- H. After checking that PV module wiring is correct, close all the junction boxes. Use a Phillips head screw driver to secure all screws on the junction box cover to ensure a waterproof seal.
- I. Refer to the cable clamp specifications for The KDxxxSX-UFBS series modules. Refer to below for a cable clamp of our designation. (Manufacturer / Part Number) Cable Gland : LAPP / S2212 (NPT-1/2") Nut : LAPP / 911371K (NPT-1/2")

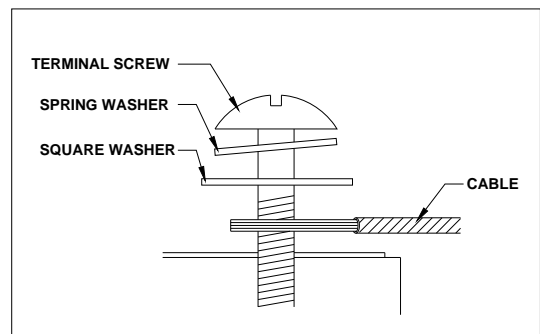

Figure 4. Ring or Spade Terminal Connectors

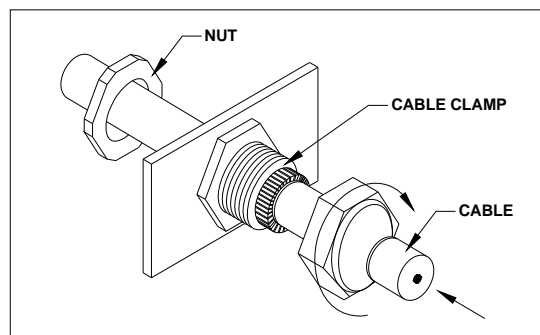

Figure 5. Installation Example of Cable Clamp

NOTE: MAXIMUM SYSTEM VOLTAGE IS 600VDC.

KD series modules and most PV system components have a maximum system voltage rating of 600 volts DC. Some grid-tie systems operate at or near this voltage rating. Like other polycrystalline solar modules, the open circuit voltage of the KDxxxSX-UFBS series module increases as the ambient temperature decreases. Maximum System voltage is computed as the sum of the open-circuit voltage of the series-connected PV modules for the lowest expected ambient temperature. Refer to the National Electrical Code Article 690-7(a) for determining the maximum number of the KDxxxSX-UFBS series modules that can be placed in series. Temperature coefficients, specific to the module of use, can be used to provide the most accurate prediction of module voltage under temperature extremes.

NOTE: Limit the maximum number of series connections of the KDxxxSX-UFBS series modules so that the system voltage is less than 600V.

NOTE: Under normal conditions, PV modules may produce more current and/or voltage than reported in the standard test conditions. Therefore, when voltage evaluations for components, capacity of conductors, size of fuses, and size of control systems connected to the module output are determined, multiply the values of short-circuit current (Isc) and open-circuit voltage (Voc) that are marked in the KDxxxSX-UFBS series modules by the factor of 1.25. Refer to Section 690-8 of the National Electrical Code for an additional multiplying factor of 1.25 which may also be applicable.

9. GROUNDING

Before installation, contact the local code authorities to determine the necessary grounding requirements. Attach all PV module frames to an earth ground in accordance with the National Electric Code (NEC) Article 250. Proper grounding is achieved by connecting PV module frames and all metallic structural members contiguously to one another using a suitable grounding conductor. The grounding conductor shall be of copper, copper alloy or another material suitable for use as an electrical conductor per NEC. The grounding conductor must then make a connection to earth using a suitable earth grounding electrode. Ensure positive electrical contact through the anodizing on PV module frame extrusion by utilizing one of the following methods. Attach the grounding conductor:

(1) to one of the 0.35" (9mm) diameter holes marked "ground" using 5/16" stainless steel hardware. Wrap conductor around bolt. Tighten the screws with adequate torque (usually 132 in-lb). Avoid direct contact of copper ground conductor to aluminum frame.

(2) to a ground lug (manufacture : ILSCO, model : GBL-4DBT). Tighten the screws with adequate torque (usually 62 in-lb). Use #10-32 stainless steel hardware to attach the lug to the module frame torque to 40 in-lb. A stainless steel star washer, positioned between the lug and the anodized surface of the frame, must be employed to break through the anodized layer of the frame extrusion and electrically connect the ground lug to the conducting aluminum frame material.

As a general rule, avoid *direct* contact of copper or copper alloyed ground conductors with the aluminum module frame. All ground bond securing hardware in contact with either the aluminum module frame and/ or copper or copper alloy ground conductors must be stainless steel.

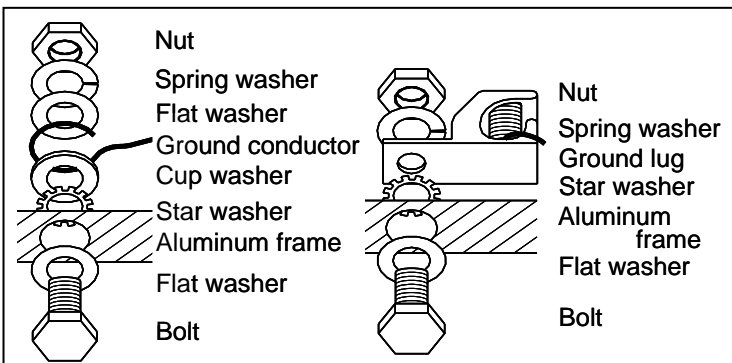

Figure 6. Installation Example of Grounding

10. BLOCKING DIODES

In systems utilizing a battery, blocking diodes are typically placed between the battery and PV module output to prevent battery from discharging at night. The KDxxxSX-UFBS series modules are made of polycrystalline cells with high electrical "back flow" resistance to nighttime battery discharging. As a result, the KDxxxSX-UFBS series modules do not contain a blocking diode when shipped from the factory. Most PV charge regulators and inverter incorporate a nighttime disconnect feature, however.

11. BYPASS DIODES

Partial shading of an individual module in a source circuit string (i.e. two or more modules connected in series) can cause a reverse voltage across the shaded cells within the module. Module output current is then forced through the shaded area by the remaining illuminated cells and other PV modules in series with the partially shaded module(s). The current forced through the shaded cells within the PV module (or modules) causes additional module heating and severe loss of power. The purpose of bypass diodes is to provide a low-resistance current path around the shaded cells, thereby minimizing PV module heating and array current losses.

The KDxxxSX-UFBS series modules employ bypass diodes that have:

- Rated Average Forward Current [I_{F(AV)}] **Above** maximum system current at highest PV module operating temperature.
- Rated Repetitive Peak Reverse Voltage [V_{RRM}] **Above** maximum system voltage at lowest PV module operating temperature.

12. MAINTENANCE

The KDxxxSX-UFBS series modules are designed for long life and require very little maintenance. Under most weather conditions, normal rainfall is sufficient to keep the module glass surface clean. If dirt build-up becomes excessive, clean the glass surface only with a soft cloth using mild detergent and water. **USE CAUTION WHEN CLEANING THE BACK SURFACE OF THE PV MODULE TO AVOID PENETRATING THE BACK SHEET.** PV modules that are mounted flat (0° tilt angle) should be cleaned more often, as they will not "self clean" as effectively as modules mounted at a 15° tilt or greater. Once a year, check the tightness of terminal screws and the general condition of the wiring. Also, check to be sure that mounting hardware is tight. Loose connections may result in a damaged PV module or array.

13. SPECIFICATIONS

Under certain conditions, a photovoltaic module may produce more voltage and current than reported at Standard Test Conditions (STC). Refer to Section 690 of the National Electrical Code for guidance in series string sizing and choosing overcurrent protection.

KYOCERA Solar Group Sales Office

■ KYOCERA Corporation
Corporate Solar Energy Group
6 Takeda Tobadono-cho Fushimi-ku, Kyoto 612-8501, Japan
Phone: 81-75-604-3476
Fax: 81-75-604-3475
<http://www.kyocera.com/>

■ KYOCERA Solar, Inc.
7812 East Acoma Drive, Scottsdale, AZ 85260, U.S.A.
Phone: 1-480-948-8003 or 1-800-223-9580
Fax: 1-480-483-6431
<http://www.kyocerasolar.com/>

■ KYOCERA Solar Pty Ltd.
Level 3, 6-10 Talavera Road, North Ryde NSW 2113, Australia
Phone: 61-2-9870-3946
Fax: 61-2-9888-9673
<http://www.kyocerasolar.com.au/>

■ KYOCERA Solar do Brasil Ltda.
Av. das Americas, 20007 – Bloco 2 – Salas (rooms) 105 to 108,
Rio de Janeiro, 22790-851, Brazil
Phone: 55-21-3724-3900
Fax: 55-21-3724-3911
<http://www.kyocerasolar.com.br/>

Table.2 The KDxxxSX-UFBS Series Module Specification

| Electrical Characteristics : @ STC | | |
|--|------------------------|------------------------|
| Model Type | KD135SX-UFBS | KD140SX-UFBS |
| Rated Power, Watts (Pmax) (W) | 135 | 140 |
| Open Circuit Voltage (Voc) (V) | 22.1 | 22.1 |
| Short Circuit Current (Isc) (A) | 8.37 | 8.68 |
| Voltage at Load (Vpm) (V) | 17.7 | 17.7 |
| Current at Load (Ipm) (A) | 7.63 | 7.91 |
| Maximum System Voltage | 600 | |
| Recommended maximum number of PV modules connected in series | 21 | |
| Factory installed Bypass Diode (Qty) | 8 | |
| Series Fuse Rating (A) | 15 | |
| Thermal Characteristics : | | |
| Temp. Coefficient of Voc (V / °C) | -0.80x10 ⁻¹ | -0.80x10 ⁻¹ |
| Temp. Coefficient of Isc (A / °C) | 5.02x10 ⁻³ | 5.21x10 ⁻³ |
| Temp. Coefficient of Vpm (V / °C) | -9.20x10 ⁻² | -9.22x10 ⁻² |
| Physical Characteristics : | | |
| Length, Inches (mm) | 59.1 (1500) | |
| Width, Inches (mm) | 26.3 (668) | |
| Depth (frame), Inches (mm) | 1.81 (46) | |
| Weight Pounds (kg) | 28.4 (12.9) | |
| Mounting Hole Diameter, Inches (mm) | 0.35 (9) Qty-4pcs. | |
| Grounding Hole Diameter, Inches (mm) | 0.35 (9) Qty-4pcs. | |
| Application Class | Class A | |

NOTES

- (1) The electrical characteristics are within +/-5% (UL verified 10% tolerance, according to UL 1703) of the installed values of Pmax and within +/-10% of the installed values of Isc and Voc under standard test conditions (irradiance of 1000W/m², AM 1.5 spectrum, and a cell temperature of 25 deg C).
- (2) See module specification sheet for most recent electrical characteristics.
- (3) See module drawing for mounting grounding holes locations.

| MODULE DIMENSIONS | | | | | | | | | | |
|------------------------------|-------|-------|-------|-------|-------|-------|-------|-------|-------|------------|
| MODULE TYPE | DIM.A | DIM.B | DIM.C | DIM.D | DIM.E | DIM.F | DIM.G | DIM.H | DIM.I | J-BOX TYPE |
| KD135SX-UFBS KD140SX-UFBS | 59.1" | 26.3" | 25.3" | 0.49" | 53.5" | 2.76" | 11.0" | 37.1" | 0.35" | IM |

KD135SX-UFBS
KD140SX-UFBS

